

LE HATKO ELECTRONICS®

Crimp Terminals & Housings
Crimpkontakte & Gehäuse
Terminal & Konnektör

Precision Metal Stamping
Präzisions-Stanztechnik
Hassas Metal Şekillendirme

Plastic Injection
Kunststoff-Spritzguss
Plastik Enjeksiyon

Surface Treatment
Oberflächentechnik
Metal Kaplama

www.hatko.com

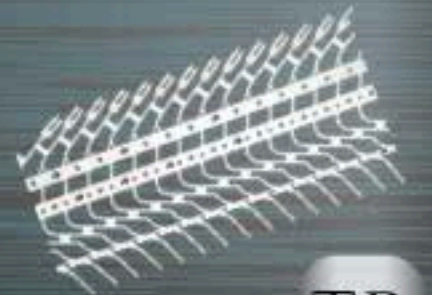
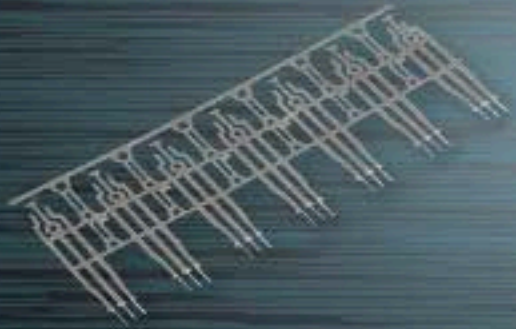

TR



1988 Yılında **Hatko Şirketler Grubu** bünyesine katılan **Hatko Electronics**, 1969 yılında kurulmuş ve Türkiye'de terminal ve konnektör üreten lider firmadır

Kendi bünyesinde bulunan ürün geliştirme, kalıp tasarım, kalıphane, preshane bölümleri ve kaplama tesisleri ile **Hatko Electronics** standart ürün portföyüne ek olarak müşterilerinin terminal ve konnektör ihtiyaçlarına özel çözümler sunabilmektedir

50 yıla yaklaşan tecrübesi ve bilgi birikimi ile **Hatko Electronics**, hem yurt içinde hem de yurtdışında, beyaz eşya, otomotiv ve elektrik/elektronik üreticileri ve yan sanayileri arasında saygın bir yere sahiptir

Hatko Electronics, müşterilerinin ihtiyaç duyduğu tüm kalite yönetim sistemleri ve ürün sertifikalarına sahiptir. Kalite sistemimiz ISO 9001 ve IATF 16949 ile belgelendirilmiş olup ürünlerimiz VDE, UL ve TÜV tarafından sertifikalandırılmıştır

UZMANLIK ALANLARIMIZ

HASSAS METAL ŐEKİLLENDİRME



PLASTİK ENJEKSİYON



METAL KAPLAMA



KALIP VE ÜRÜN TASARIMI & KALIP ÜRETİMİ



KRİMP TEKNOLOJİSİ



DEĞERLERİMİZ

ALMAN
TEKNOLOJİSİ



MÜŞTERİ
ODAKLI



KALİTE
ÖNCELİKLİ



ESNEK ADETLER &
TERMİNLER



PROJE / TASARIM
YARATICILIĞI



ÖZEL GELİŞTİRİLMİŞ
ÜRÜNLER



ÜRÜNLERİMİZİ 5 KİTAYA TEDARİK EDİYORUZ...



HASSAS METAL ŞEKİLLENDİRME

“TERMİNAL ÜRETİMİ VE ÖTESİ...”

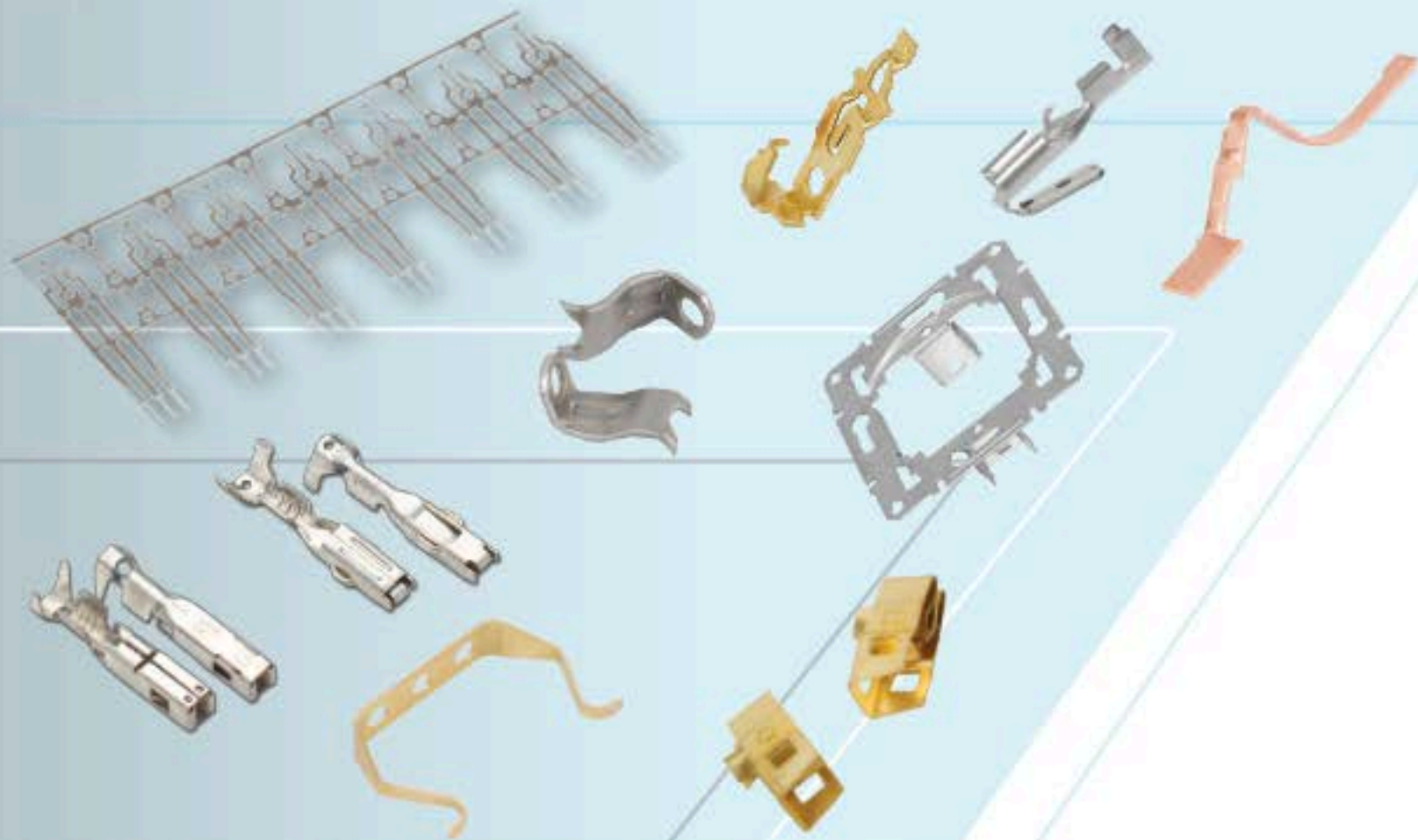

- ✓ Terminal, Metal Parça ve Güç Dağıtım Parçaları üretimi
- ✓ Modern ve son teknolojik özelliklere sahip üretim hattı
- ✓ Kullanılan hammaddeler:
 - Pirinç «
 - Fosfor-Bronz «
 - Bakır-Nikel «
 - Çelik «
 - Krom-Nikel «
 - Bakır «
- ✓ 2,5 mm kalınlık, 100 mm genişliğe kadar üretim tekniği
- ✓ Uluslararası standartlara uygunluk: DIN, EN, IEC

HASSAS METAL ŞEKİLLENDİRME

“SON TEKNOLOJİ ÜRETİM HATTI”

Bruderer Preslerimiz

- ✓ 25-51 ton pres gücü
- ✓ 1200 devir/dak. hıza kadar üretim
- ✓ 0,15-1,5 mm sac kalınlığı
- ✓ Değişken strok (13-51 mm)
- ✓ 8-100 mm bant genişliği
- ✓ Çift malzeme ile üretim imkanı

Standart Preslerimiz

- ✓ 25-100 ton pres gücü
- ✓ 300 devir/dak. hıza kadar üretim
- ✓ 0,40-2,5 mm sac kalınlığı
- ✓ Sabit strok (40-51-70 mm)
- ✓ 10-150 mm bant genişliği



PLASTİK ENJEKSİYON

PLASTİK İZOLELERİN ÜRETİMİ



Krauss Maffei Enjeksiyon Makinelerimiz

- ✓ 65-80-125 ton üretim kapasitesi
- ✓ 5-275 gr ağırlığında parça üretim imkanı
- ✓ Malzeme dizayn ve kullanım alanına bağlı olarak hammadde seçimi:
 - Polyamide (PA) «
 - Polyvinyl Chloride (PVC) «
 - Polyethylene (PE) «



PLASTİK ENJEKSİYON

ÖRNEK KONNEKTÖRLER

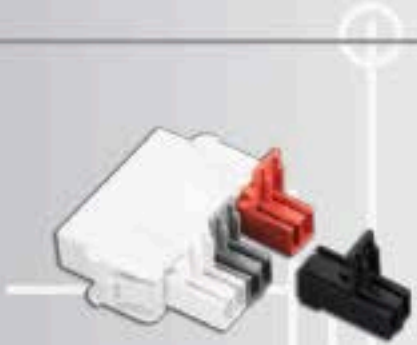

USK Serisi Konnektörler



13'lü Konnektörler

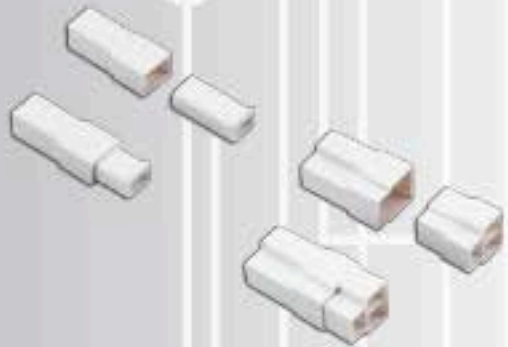

1-8 Kutuplu Konnektörler



SF22 Serisi Konnektörler



METAL KAPLAMA

TÜRKİYE'NİN TEK ELEKTROLİTİK
"REEL TO REEL"
KAPLAMA TEKNOLOJİSİ

"Alman Yapımı Reel-to-Reel Kaplama Tesisleri"

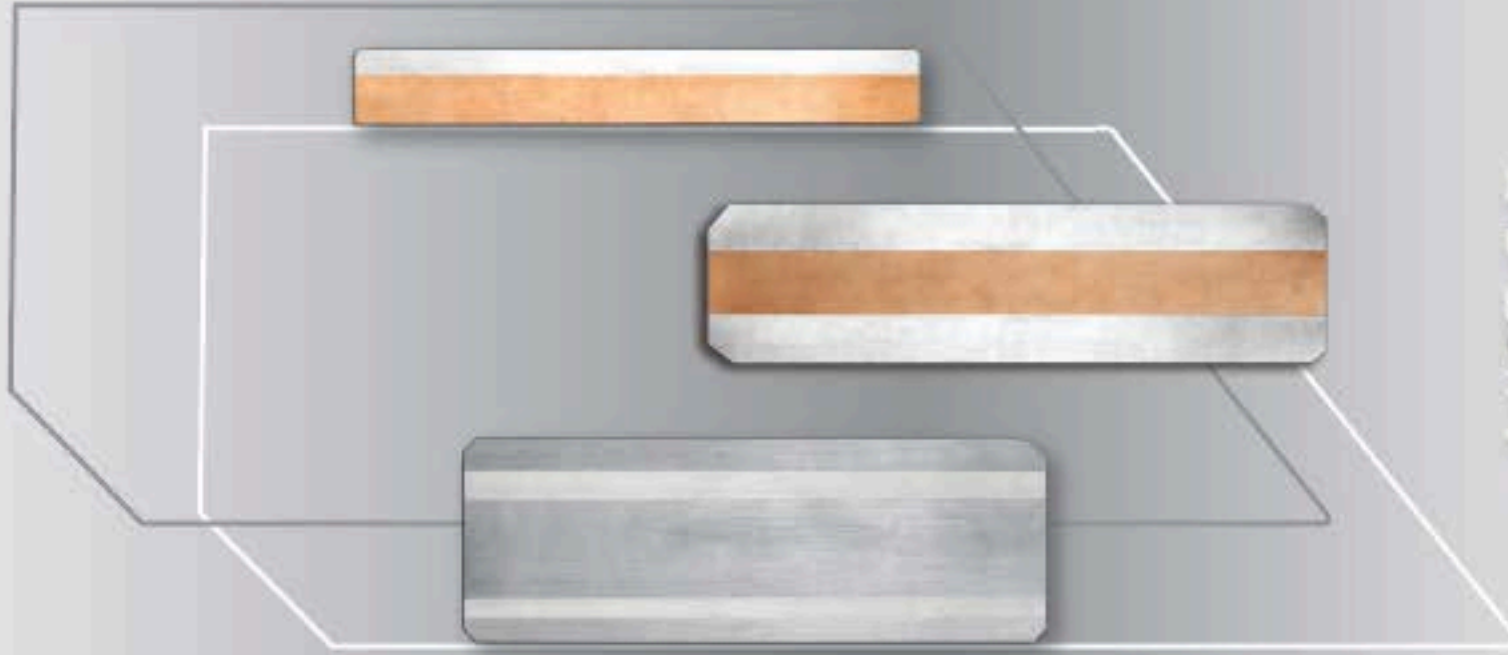

Bant Kalınlığı: Maksimum 1,5 mm
Bant Geniřliđi: Maksimum 70 mm

METAL KAPLAMA

Kaplama Tipleri

Altın (AuCo) + Pasivasyon

Gümüş + Pasivasyon (metal ve organik bazlı)

Kalay (Parlak ve Mat)

Nikel (Duktil, Parlak ve Mat)

Bakır

Çoklu Kaplama

Bölgesel Selektif Kaplama



KALIP VE ÜRÜN TASARIMI

“ ÜRÜN TASARIMINDAN
KALIP YAPIMINA...”

Plastik ve metal ürünler için yüksek hızlı, modüllü ve progresif kalıpların tasarımı ve imalatı

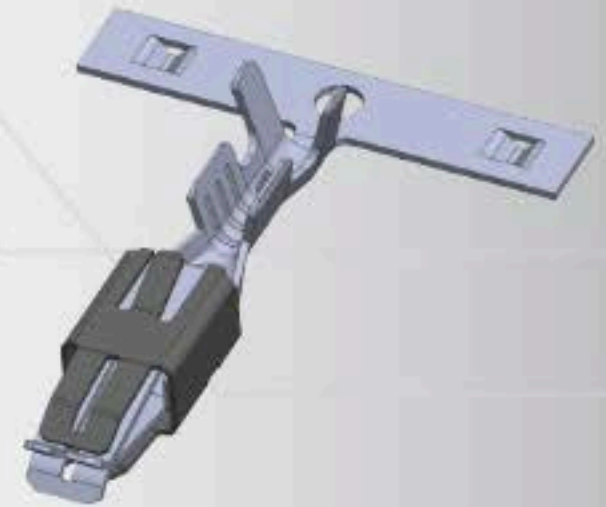
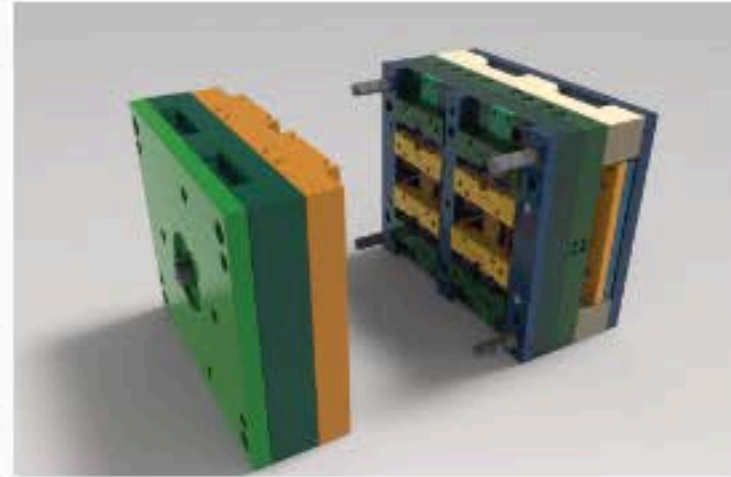

KALIP ÜRETİMİ

“MODERN KALIPHANE
MAKİNE PARKURU”

- ✓ DECKEL MAHO HSC 55-1 FREZE
- ✓ MİKRON CNC FREZE
- ✓ JUNG SATIŞ TAŞLAMA
- ✓ WASİNO OPTİK TAŞLAMA
- ✓ AGIE DRILL20 CNC DELİK EROZYON
- ✓ AGIE AC PROGRESS VP3 TEL EROZYON
- ✓ AGIE CHARMILLES DALMA EROZYON



KRİMPLEME TEKNOLOJİSİ

- ✓ Müşteri odaklı servis ve çözümler
- ✓ Krimpleme desteği
- ✓ Krimp ekipmanları üretimi
- ✓ Krimp kesit ölçümü
- ✓ Krimp testleri
- ✓ Microsection raporları

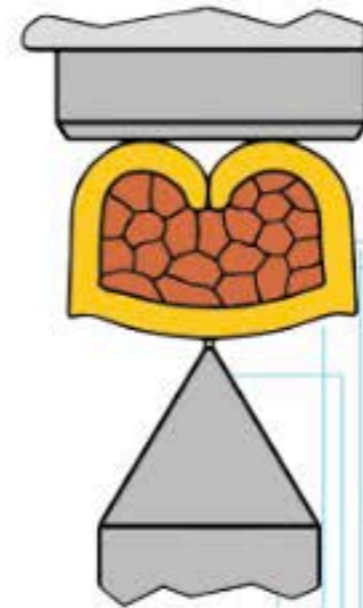
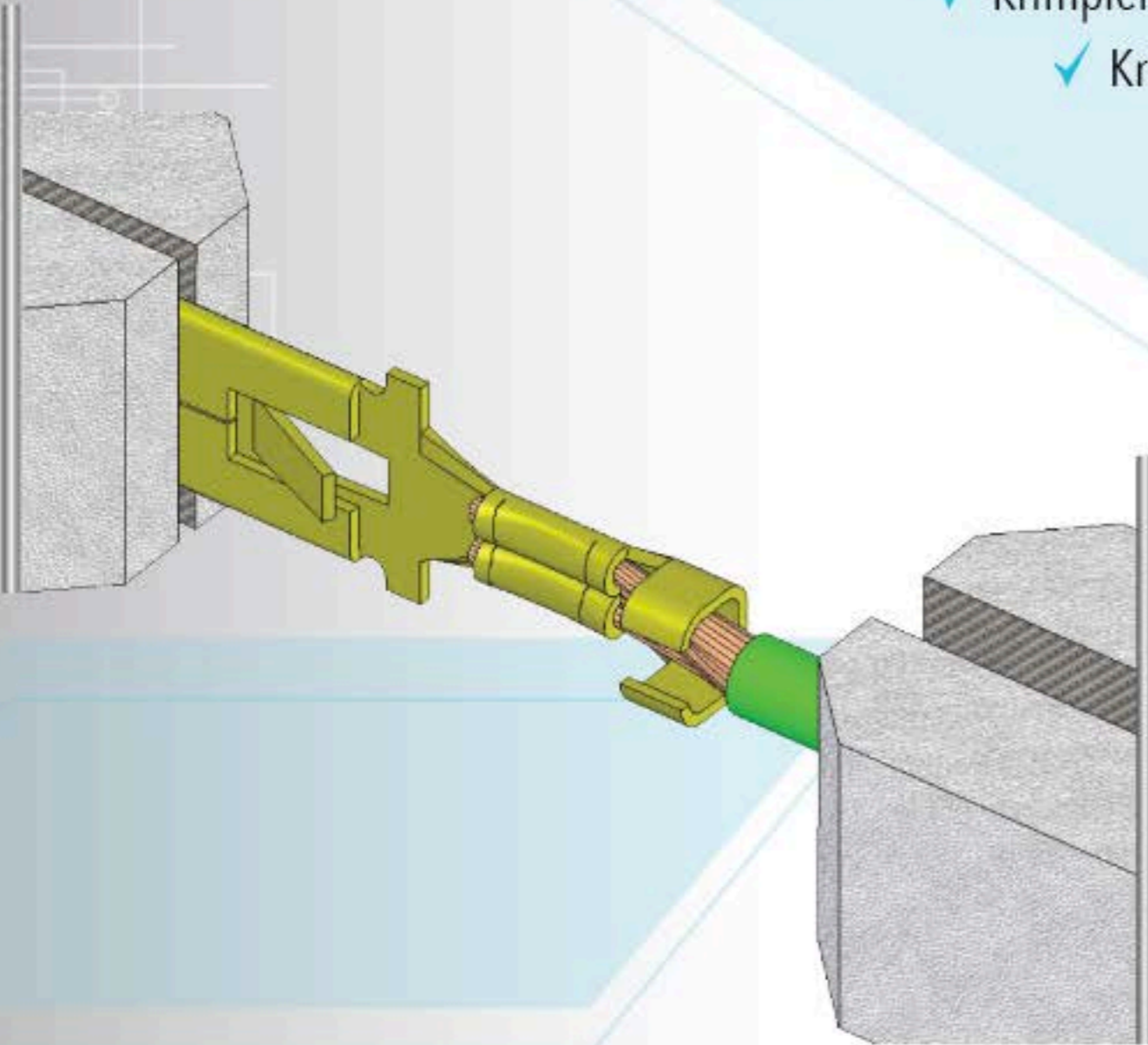
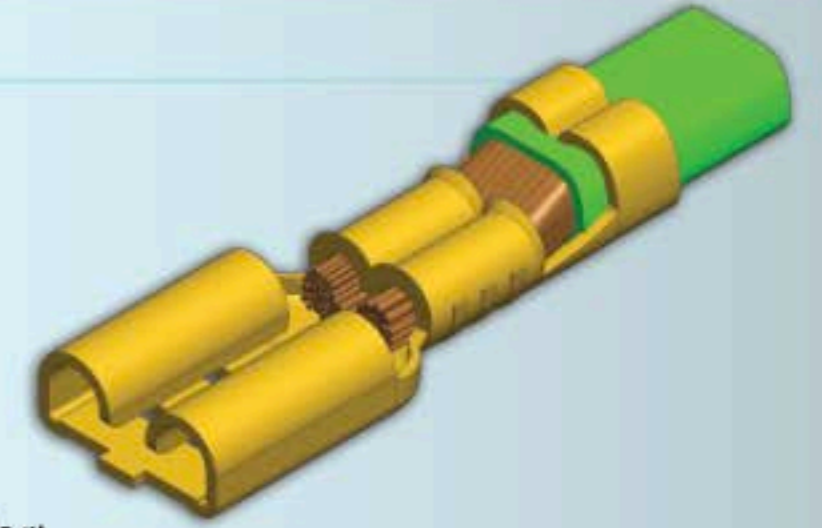

KRİMPLEME TEKNOLOJİSİ



Kapama Presi

- ✓ Yarı otomatik tezgah üstü krimp presi
- ✓ Sessiz ve kolay kullanım
- ✓ Aydınlatma lambası ve plastik muhafaza
- ✓ Günlük sıfırlanabilen 100 milyonluk sayaç



Çene ve Örs Takımları

- ✓ Standart çene ve örs takımları
- ✓ Müşteri taleplerine özel ölçülerde üretim
- ✓ Aşınmaya karşı dayanıklı parçalar

Kapama Kalıbı

- ✓ Zincir halinde makaraya sarılmış terminaller için
- ✓ Hızlı üretim, arttırılmış verimlilik
- ✓ Mekanik adım ayar imkanı



KALİTE STANDARTLARIMIZ

“KALİTE STANDARTLARIMIZI
SON MODEL
KALİTE EKİPMANLARIMIZ İLE
SAĞLAMAKTAYIZ...”

Sektörlerimizin gerektirdiği tüm kalite sertifikalarına sahibiz

Ürünlerimiz DIN, EN ve IEC gibi uluslararası standartlara uygun olarak üretilmekte olup firmamız ayrıca birçok ürün grubunda VDE, UL ve TÜV ürün sertifikalarına sahiptir



ISO 9001:2015 Kalite Yönetim Sistemi



IATF 16949:2016 Otomotiv Kalite Yönetim Sistemi



VDE Ürün Teknik Kalite Sertifikası



UL Ürün Teknik Kalite Sertifikası



TÜV Ürün Teknik Kalite Sertifikası



EAC Rusya Ürün Teknik Kalite Sertifikası



RoHS/REACH Analiz ve Deklarasyonları



KALİTE UYGULAMALARIMIZ



Üretim hatlarında video/görüntü teknolojisi ile kontrol

| | |
|------------------------|---|
| PPAP Dökümantasyonları | ✓ |
| Ölçüm | ✓ |
| Test ve Kontrol | ✓ |
| Video Kontrol | ✓ |

Avrupa standartlarında ölçüm, kontrol ve onaylama



ÜRÜN GRUPLARIMIZ

DÜZ TİP DİŞİ
TERMİNALLER



YUVARLAK ERKEK
TERMİNALLER



DÜZ TİP ERKEK
TERMİNALLER



BAYRAK TİP
TERMİNALLER



TOPRAKLAMA
TERMİNALLER



KONNEKTÖRLER &
KILIFLAR



LİF TERMİNALLER



ÇATAL TİP
TERMİNALLER



KLEMENSLER



ÖZEL TİP
TERMİNALLER



EK TERMİNALLER



PCB KONNEKTÖRLER



YUVARLAK DİŞİ
TERMİNALLER



BORU TİP
TERMİNALLER



DİĞER ÜRÜNLER



DÜZ TİP DİŞİ TERMİNALLER



BAYRAK TİP TERMİNALLER



LİF TERMİNALLER



ÖZEL TİP TERMİNALLER



YUVARLAK DİŞİ TERMİNALLER



YUVARLAK ERKEK TERMİNALLER



TOPRAKLAMA TERMİNALLERİ



ÇATAL TİP TERMİNALLER



EK TERMİNALLER



BORU TİP TERMİNALLER



DÜZ TİP ERKEK TERMİNALLER



KONNEKTÖRLER & KILIFLAR



KLEMENSLER



PCB KONNEKTÖRLER



ÖZEL ÜRÜNLER

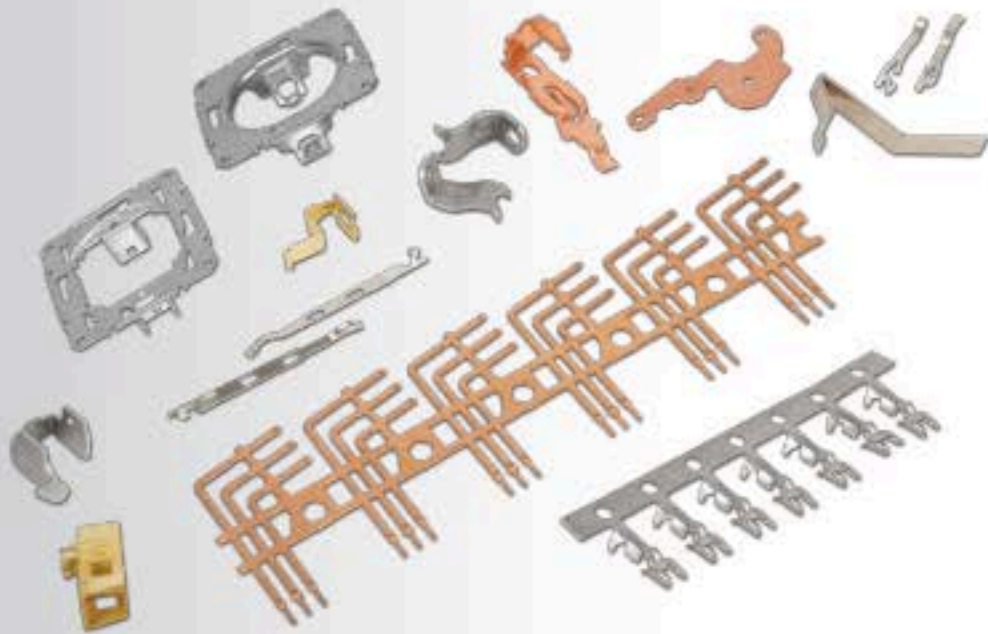

DİĞER ÜRÜNLER

MONTAJLANMIŞ ÜRÜNLER

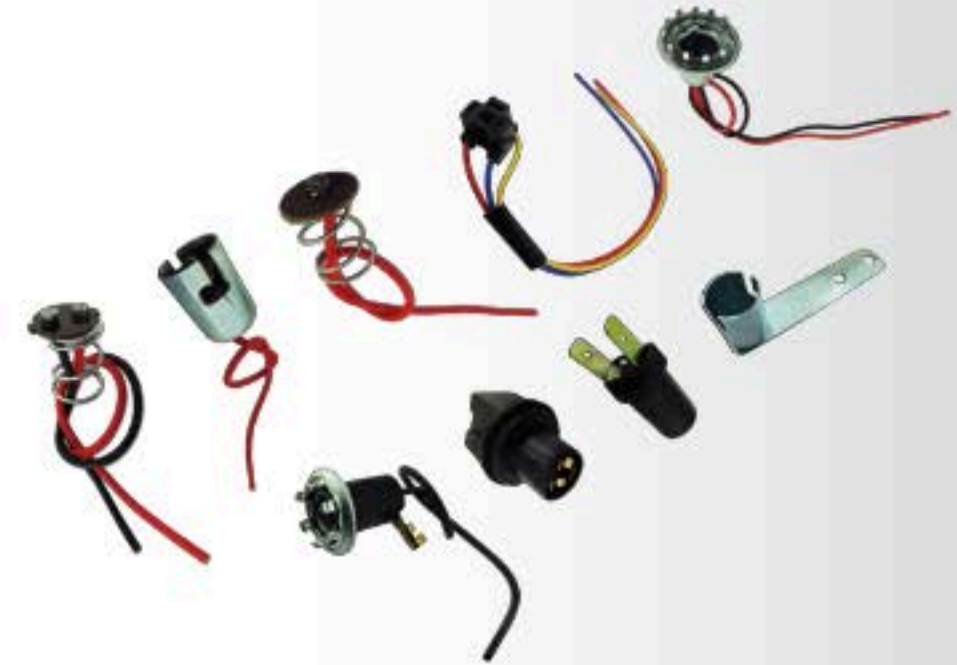

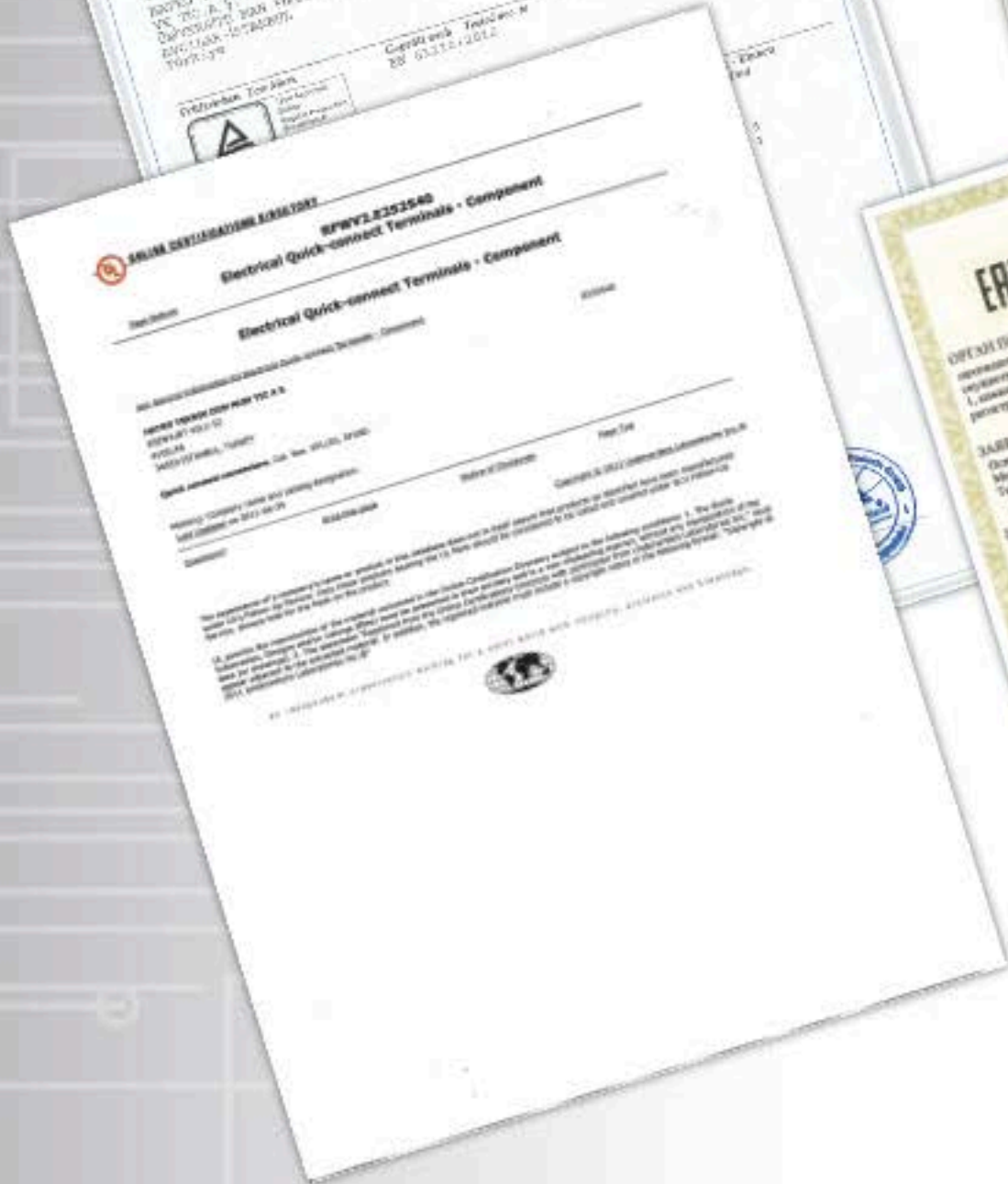
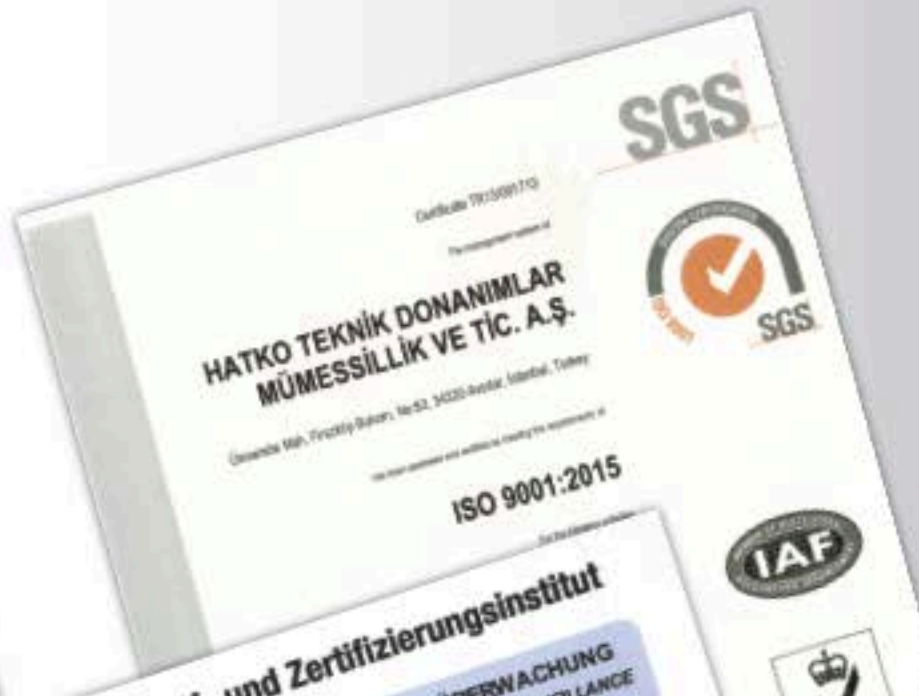

HATKO ELECTRONICS®

Crimp Terminals & Housings
Crimpkontakte & Gehäuse
Terminal & Konnektör

Precision Metal Stamping
Präzisions-Stanztechnik
Hassas Metal Şekillendirme

Plastic Injection
Kunststoff-Spritzguss
Plastik Enjeksiyon

Surface Treatment
Oberflächentechnik
Metal Kaplama

Üniversite Mahallesi Firuzköy Bulvarı No:52 Avcılar 34320 İstanbul / Turkey

Tel: +90 (212) 591 35 20

info: sales@hatko.com

Website: www.hatko.com

